

Jones Mechanical Tachometers with Tell-tale

Jones Tachometers are considered by many racers to be the world's finest mechanical tachometers. We only stock the highest quality sealed unit with tell-tale. The 3" nominal size mounts in a 3 3/8" hole in the dash panel. The 4" nominal size mounts in a 4 3/8" diameter hole. Our stock tachs have the standard side reset for the tell-tale and the cable input fitting on the back. A nice feature on these tachs is that the input is non-directional. No need to worry about reversing gearboxes. Just make sure to order the correct drive ratio. The 4:1 ratio is usually needed when driving from a Smith's right angle gearbox and the 2:1 ratio when driving directly from a cam or distributor without the speed reduction gearbox. If in doubt, count how many crankshaft revolutions are required to make the tach cable complete one turn. Other configurations can be special ordered including alternate ranges and alternate tell-tale reset locations.

- 3 inch, 10,000 rpm, with tell-tale, 2:1 ratio Part No. 1370-10-2:1 \$450.00
- 3 inch, 10,000 rpm, with tell-tale, 4:1 ratio Part No. 1370-10-4:1 \$450.00
- 3 inch, 12,000 rpm, with tell-tale, 4:1 ratio Part No. 1370-12-4:1 \$450.00
- 4 inch, 10,000 rpm, with tell-tale, 2:1 ratio, black bezel Part No. 1374-10-2:1 \$428.00
- 4 inch, 10,000 rpm, with tell-tale, 4:1 ratio, black bezel Part No. 1374-10-4:1 \$428.00
- Smith's cable adapter (attaches to tach, connects to Smith's cable) Part No. 1380 \$16.99
- Stewart-Warner cable adapter (attaches to tach, connects to S-W cable) Part No. 1379 \$13.99
- 90° Cable Adapter — mounts to back of tach (1:1 drive ratio) Part No. 1387 \$97.99

The adapter can be rotated to allow the cable to approach from any direction perpendicular to the tach input.



Jones 3 inch Mechanical Tachometer
Part No. 1370-12-4:1

Stack Chronotronic Tachometer

**STACK
STACK
STACK**



The **Stack Chronotronic Tach** is an accurate replica of the original Smiths Chronometric tach with a modern twist. When the engine is running above 5000 rpm, the solid-state electronics provide the same solid, no-waver operation as on other Stack tachs. Below 5000 rpm, the microprocessor controlled stepper motor mimics the original Chronometric "Needle-freeze" movement. Classic styling features a chrome bezel, lighter needle, and black 0-10,000 rpm dial face. Even the Stack logo and rpm markings have been given a retro treatment to re-create the look of the original. Modern updates include maintenance-free white LED backlighting, peak RPM tell tale memory, sealed waterproof case, and shift light output (shift lights sold separately on page 34). Fits the same 3.5" (88mm) cutout as the original Smiths tach. User-configurable to suit different engine configurations. Compatible with all 12V negative-ground ignition systems including magnetos. Supplied with mounting bracket, switch kit and instruction manual. Covered by a 12 month competition warranty.

Stack Chronotronic Tachometer with "Needle-freeze" movement Part No. ST901096 \$598.00

GAUGES

Drive Adapters for Mechanical Tachometers

Crank Shaft Drive Adapter



Crankshaft Adapter
Part No. 1386
(shown with
optional clamp)

If your engine doesn't lend itself to driving a tach from the cam or distributor, then this quality 2:1 reduction gearbox may be the answer. It is designed to mount in front of the crankshaft. Just drill a 9/32" hole in the end of the crankshaft or in the head of the crankshaft front bolt to accept the drive bushing. A short flex cable with square ends transmits the rotation to the gearbox while allowing a reasonable amount of misalignment.

You will need to fabricate a mounting bracket to hold the gearbox. A 1.5 inch diameter boss is provided on the gearbox to make it easy to attach it to the bracket. You may want to use one of our heavy-duty vinyl coated clamps (Part No. 3298-1.50) to attach the gearbox to your bracket. The output is a 7/8-18 thread with .187 tang drive (use with cable Part No. 1385 for Jones tachs). Use tachs with 2:1 drive ratio.

- Front Crank Adapter with connecting shaft and bushing Part No. 1386 \$94.99
- Extra Hardened Drive Bushing for crank or crank front bolt Part No. 1389 \$14.89
- Replacement Adapter Drive Cable, 2.75 inch overall length Part No. 1391 \$19.99
- 1.50 inch Heavy-Duty Vinyl Coated Clamp Part No. 3298-1.50 \$2.19

Cam Shaft Drive Adapter

This quality unit is manufactured by Jones; it can also be used with Stewart-Warner mechanical tachs. To install, bore a 15/16" hole in the cam cover in line with the cam and drill a 9/32" hole in the cam or timing gear to accept the drive bushing.

Four beveled washers can be rotated to allow up to 6 degrees of casting draft or contour on the cover. The shaft is sealed against oil leakage. The output is a 7/8-18 thread with .187 tang drive (use with cable Part No. 1385 for Jones tachs). Since Jones tachs are not direction sensitive you can drive off the front or rear of the cam. With Stewart-Warner tachs you must insure proper direction. Use tachs with 2:1 ratio.

- Complete Cam Adapter with Cam Bushing Part No. 1388 \$59.99
- Extra Hardened Drive Bushing for Cam Shaft Part No. 1389 \$14.89



Direct Drive Cam Adapter
Part No. 1388

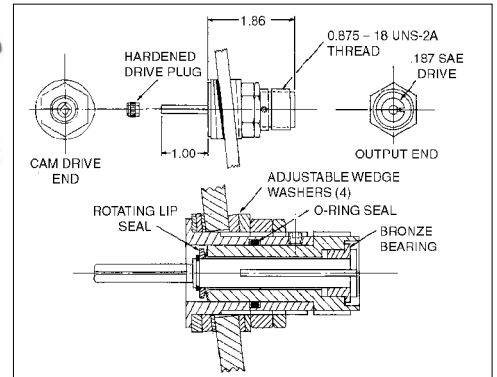

Tach Drive Gearbox as used on Ford 1.6L and 2.0L Racing Engines



Tach Drive Gearbox
Part No. 166-20
(Part No. 176-20
looks the same)

This gearbox provides 2:1 speed reduction. Since it is driven by the cam or oil pump which is already turning at 1/2 crank speed, the cable actually turns at 1/4 crank speed. Therefore, a 4:1 tach must be used with this type of gearbox.

A black dot on the bearing cap indicates correct rotation when used with Smith tachs. Jones tachs are not direction sensitive and can be driven in either direction.

- Tach Drive Gearbox for 1.6L (brown dot) Part No. 166-20 \$289.00
If input is clockwise, output is counterclockwise (reversing).
- Tach Drive Gearbox for 2.0L (black dot) Part No. 176-20 \$289.00
If input is clockwise, output is clockwise (non-reversing).

See page 61 for other tach drive components.